

## DESIGN EXAMPLE V1

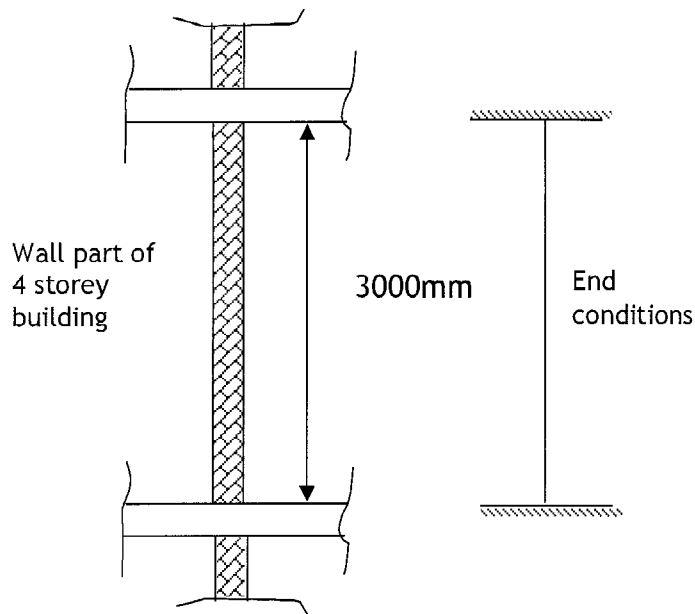

Design vertical load = 180 kN/m with no applied eccentricity of loading

Find the characteristic strength ( $f_k$ ) of masonry made from Group 1 clay brick masonry units of standard format size with a normalised compressive strength ( $f_b$ ) of 42,5 N/mm<sup>2</sup>. The attestation of conformity (manufacturing control) is Category II and the masonry will be constructed using an M4 general purpose mortar using Class 2 execution control. Check that the load capacity of such a wall is sufficient to withstand the loading applied.

Recalculate the above using Group 1 concrete block masonry units with a normalised compressive strength ( $f_b$ ) of 20 N/mm<sup>2</sup>. The masonry units are 140mm in thickness.

Ignore the self weight of the wall.