

R3 Solution. Reinforced Hollow Concrete Blockwork Column Subjected To Uniaxial Bending

The exposure situation given is MX2 and therefore 25mm minimum concrete cover to main reinforcing steel is required from Table NA.9 of the UK National Annex (stainless steel will be used in column links which are partially bedded in mortar and in concrete infill and so 20mm minimum cover is appropriate to links to achieve bond and practical cover). Isolation of links and main steel required at isolated positions of contact by taping etc.

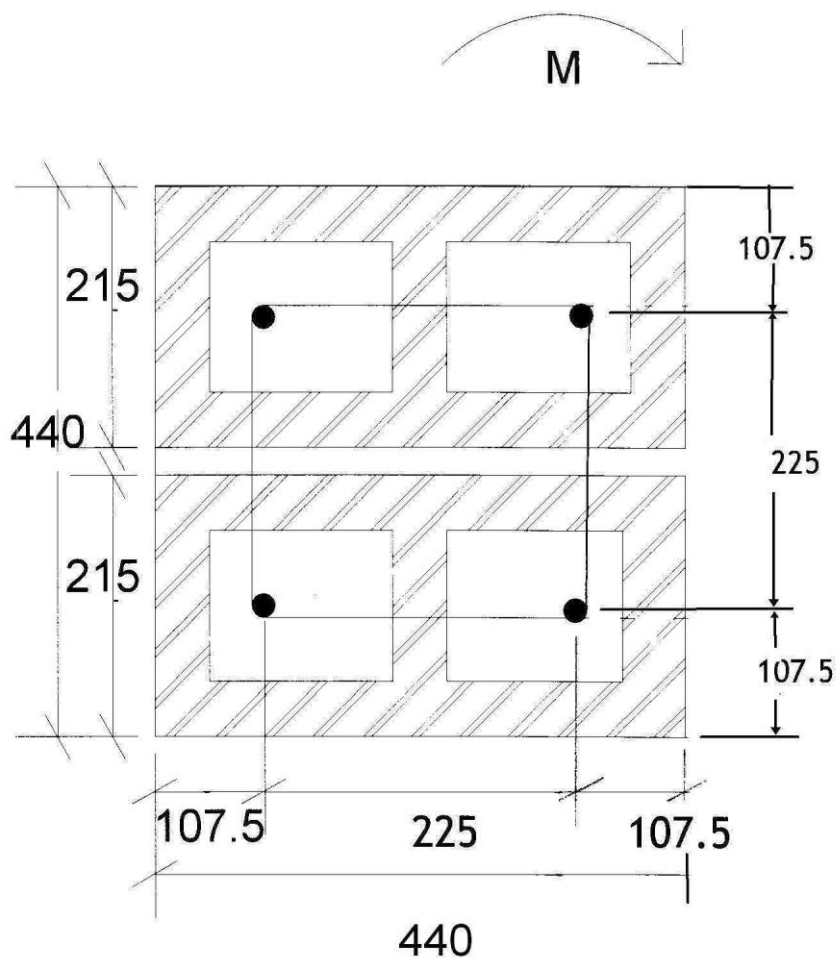

Figure 1: Position of reinforcement in column

The guidance in BS EN 1996-1-1 on the design of columns when the design axial load, σ_d , exceeds 30% of the masonry design strength, f_d , is limited for combined bending and axial loading and reference to clause 8.3.3 of BS 5628 Part 2 is required, although the partial safety factors, characteristic

strengths, effective height, effective thickness and slenderness ratios should be those relevant to BS EN 1996-1-1. In due course a BSI Provisional Draft (PD) will be produced to cover aspects not given by the Eurocode and these are likely to be mainly based upon BS 5628 Part 2 guidance.

The normalised compressive strength of the masonry unit is given by:

$$f_b = 10,4 \text{ N/mm}^2 \times 1,0 \times 1,16$$

$$f_b = 12,06 \text{ N/mm}^2$$

where 1,0 is the conditioning factor and 1,16 is the shape factor both taken from BS EN 772 Part 1.

The strength of the unit based on the net area is calculated as:

$$12,06 \times 100\%/65\% = 18,55 \text{ N/mm}^2$$

As this strength is lower than that of the concrete infill to be used the masonry is designed as having an equivalent gross compressive strength based on that of a solid masonry unit (Group 1 solid) with a normalised compressive strength equal to that of the net area block strength as

$$f_b = 18,55 \text{ N/mm}^2$$

Therefore $f_k = K f_b^{0,7} f_m^{0,3}$ where $K = 0,55$ from UK National Annex, thus:

$$f_k = 0,55 \times 18,55^{0,7} \times 6,0^{0,3}$$

$$f_k = 7,27 \text{ N/mm}^2$$

Therefore $f_d = f_k / \gamma_M = 7,27 / 2,3 = 3,16 \text{ N/mm}^2$ using category I units with class 1 execution control ($\gamma_M = 2,3$ for the unreinforced section capacity check)

And $\sigma_d = 400 \text{ kN} \times 10^3 / 440 \times 440 = 2,07 \text{ N/mm}^2$ (therefore $\sigma_d = 0,65 f_d > 0,3 f_d$)

Assume top and bottom of columns have lateral supports restricting movement in both directions with effective height factor, $\rho_2 = 1,0$.

Therefore $h_{ef} = 3000 \times 1,0 = 3000 \text{ mm}$

t_{ef} = minimum thickness = 440 mm

Slenderness ratio = $3000 / 440 = 6,82$

This is less than 12, therefore column is short and can be designed using the additional principles from clause 8.3.3.1 of BS5628 Part 2.

Check whether only minimum reinforcement required from:

$$N_{Rd} = f_d b (t_o - 2e_i)$$

Resultant eccentricity, $e_i = (45,0 \times 10^6) / (400,0 \times 10^3) = 112,5 \text{ mm}$

And $f_d = f_k / \gamma_M = 7,27 / 2,0 = 3,64 \text{ N/mm}^2$ ($\gamma_M = 2,0$ for reinforced section capacity)

$$N_{Rd} = 3,64 \times 440 (440 - 2 \times 112,5) \times 10^{-3}$$

$$N_{Rd} = 344,3 \text{ kN}$$

This is less than design vertical load N_{Ed} of 400 kN, therefore designed reinforcement is required.

Consider stress distribution across section

Assume $d_{cm} = t_0 - d_2$ and $f_{s2} = 0$

Provide 2 no. 20mm diameter deformed Grade 500 steel bars each face (4no. total); area of 2 no. bars = 628mm²

And $f_{yd} = 500/1,15 = 435\text{N/mm}^2$

From:

$$N_{Rd} = f_d b d_{cm} + \frac{f_{s1}}{\gamma_M} A_{s1} - \frac{f_{s2}}{\gamma_M} A_{s2}$$

$N_{Rd} = (3,64 \times 440 \times 332,5 \times 10^{-3}) + (0,83 \times 500 \times 628 \times 10^{-3} / 1,15) - 0$ using $0,83f_{yk}/\gamma_M$ as $0,83f_{yd}$ from BS5628 Part 2

$N_{Rd} = 532,5 + 226,6 \text{ kN}$

$N_{Rd} = 759,1 \text{ kN} > 400 \text{ kN}$

From:

$$M_{Rd} = 0,5f_d b d_{cm} (t_0 - d_{cm}) + 0,83f_{yd} A_{s1} (0,5t_0 - d_1) + f_{yd} A_{s2} (0,5t_0 - d_2)$$

$M_{Rd} = \{0,5 \times 3,64 \times 440 \times 332,5 \times (440 - 332,5) \times 10^{-6}\} + \{(0,83 \times 435 \times 628 \times (0,5 \times 440 - 107,5) \times 10^{-6})\} + 0$

$M_{Rd} = 28,6 + 25,5$

$M_{Rd} = 54,1 \text{ kN.m} > 45 \text{ kN.m}$

Thus N_{Rd} exceeds N_{Ed} and M_{Rd} exceeds M_{Ed} and the section is therefore adequate.

Column link reinforcement:

$A_s = 4 \times 314 = 1256 \text{ mm}^2$ for main vertical steel

Therefore steel % of section = $(1256 \times 100 / 440 \times 440) = 0,65\%$ which is greater than 0,25%

And vertical design load % = $(400,0 \times 100 / 759,1) = 53\%$ which is greater than 25%

From Clause 8.2.6 links are required with vertical spacing as lesser of:

- 440 mm
- 300 mm
- $12 \times 20 = 240 \text{ mm}$ which therefore governs

Provide 6mm diameter plain bar strength Grade 200 Austenitic stainless steel column links at 225 mm vertical spacing to suit block coursing dimensions.

If actual and the effective height of column are increased to 6,0m Slenderness ratio becomes $6000/440 = 13,6$ and column becomes slender that is slenderness ratio greater than 12, but less than the limiting value of 27.

An additional moment, M_{ad} , must therefore be allowed for as:

$$M_{ad} = N_{Ed} h_{ef}^2 / 2000 t \quad \text{Eqn. 6.25}$$

$$M_{ad} = (400,0 \times 6,0^2 / 2000 \times 0,440)$$

$$M_{ad} = 16,4 \text{ kN.m}$$

Design moment M_{Ed} becomes $45 + 16,4 = 61,4 \text{ kN.m}$

From the above it will be seen that N_{Rd} unmodified still exceeds N_{Ed} for the slender column situation, but M_{Rd} is now less than M_{Ed} so reinforcement will be increased to 4 no. 25mm diameter main reinforcing bars.

$$M_{Rd} = \{0,5 \times 3,64 \times 440 \times 332,5 \times (440 - 332,5) \times 10^{-6}\} + \{(0,83 \times 435 \times 982 \times (0,5 \times 440 - 107,5) \times 10^{-6}\} + 0$$

$$M_{Rd} = 28,6 + 39,9 \text{ kN}$$

$$M_{Rd} = 68,5 \text{ kN.m} > 61,4 \text{ kN.m}$$

Thus M_{Rd} exceeds M_{Ed} and the section is therefore adequate using 4 no. 25mm diameter reinforcing bars.

The effect of the slender column is therefore to increase the reinforcement requirement from 20mm diameter to 25mm diameter bars in the reinforced masonry column. Column links for practical spacing purposes remain the same as before.