

## R2: Solution. Reinforced Brickwork Beam

The effective depth will be based upon the limiting span to depth ratios given in BS EN 1996-1-1, the coordinating dimensions of brickwork coursing and if critical the shear strength of the beam section.

In order to suit the supporting piers width make beam width,  $b = 440$  mm. Use bricks as soldier courses for aesthetic reasons and so that brickwork in compression is loaded normal to its bed face. Which is compatible with their test procedure and the declared compressive strength of the brick masonry units.

*(It should be noted that if brickwork is laid horizontally such that it is loaded in compression across its stretcher face,  $f_k$  and  $f_d$  must be determined in relation to the actual direction of structural loading).*

Trial section is as shown in diagram. As arrangement of section and concrete infilling will allow shear links to be used shear is unlikely to control the effective depth,  $d$ .

Overall beam depth = 553mm

Assume Exposure situation MX3 with C35/45 infilling concrete to inner void and actual cover provided to reinforcement is 20mm minimum

As Table NA.9 of the UK National Annex requires a minimum cover of 30mm for this exposure situation austenitic stainless steel reinforcing bars and shear links will be used throughout. 20mm minimum cover required to achieve bond and practical cover requirements.

Effective depth,  $d = (553 - 103 - 20 - 8 - 10) = 412$ mm ( $d = 410$ mm)

Now actual effective span,  $l_{ef} = (3800 + 410) \times 10^{-3} = 4,21$ m assuming in this case that  $d$  is less than the supporting piers width ( $t_1/2 + t_2/2$ ).

Span/effective depth ratio must not exceed 20 from Table 5.2, therefore max. allowable effective span,  $l_{ef} = 20 \times 410 \times 10^{-3} = 8,20$ m for the serviceability conditions of deflection and cracking

This is greater than the actual effective span of 4,21m.

And  $l_r$  limiting =  $60b_c$  or  $250b_c^2/d$  whichever is the lesser from Eqns. 5.13 and 5.14 respectively, therefore:

$60b_c = 60 \times 0,440 = 26,4$  m  $> 4,21$ m therefore satisfactory, and

$250b_c^2/d = 250 \times 0,440^2 / 0,410 = 118,05$ m  $> 4,21$ m therefore also satisfactory.

Consider the design load =  $1,35G_k + 1,5Q_k$

where 1,35 and 1,5 are the partial safety factors for the unfavourable effects of permanent and variable loads in accordance with BS EN 1990 and the UK National Annex.

Design Load =  $1,35 \times 20,0 + 1,5 \times 8,0$

Design Load = 39,00kN/m run

The simply supported design moment is:

$M_{Ed} = 39,00 \times 4,21^2 / 8 = 86,40$ kN.m

The design shear force is:

$$V_{Ed} = 39,00 \times 4,21 / 2 = 82,10\text{kN}$$

### Section bending capacity

The design bending moment,  $M_{Ed}$ , is 86,40kN.m

The declared compressive strength of the brick masonry units is 40N/mm<sup>2</sup>

Thus normalised compressive strength of the bricks,  $f_b$ , is given by:

$$f_b = 1,0 \times 0,85 \times 40\text{N/mm}^2$$

$$f_b = 34,0\text{N/mm}^2$$

where test moisture conditioning factor is 1,0 and 0,85 is the shape factor  $\delta$ , both taken from BS EN 772 Part 1.

The characteristic compressive strength of the brickwork is given by:

$$f_k = K f_b^{0,70} f_m^{0,30} \text{ for General Purpose mortar use}$$

where K is taken as 0,5 for Group 1 clay masonry units in accordance with Table NA.4 of the UK National Annex, hence:

$$f_k = 0,5 \times 34,0^{0,7} \times 6,0^{0,3}$$

$$f_k = 10,10\text{N/mm}^2$$

And  $f_d = f_k / \gamma_M = 10,10 / 2,0 = 5,05\text{N/mm}^2$  where  $\gamma_M$  is 2,0 for category I units with class 1 execution control from UK National Annex.

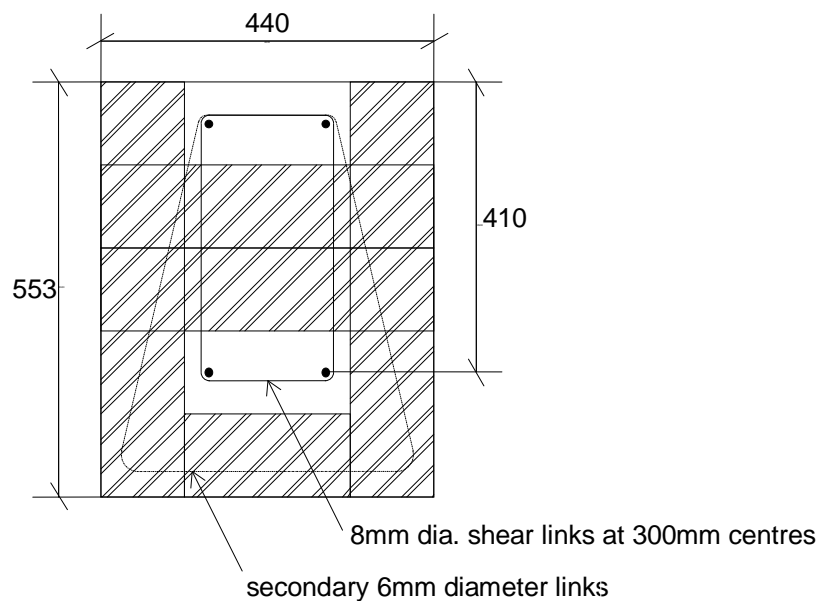

Figure 1: Arrangement of steel in the beam

Design moment of resistance of beam in tension:

Using the  $Q$  factor approach from BS5628 Part 2 which is compatible with the Eurocode 6 methodology then:

The moment of resistance factor  $Q$  is given by:

$$Q = M_{Ed} / bd^2 = 86,40 \times 10^6 / 440 \times 410^2 = 1,168$$

$$\text{And } Q = 2c(1-c)f_d$$

Therefore  $1,168 = 10,10c - 10,10c^2$  and solving for  $c$   
 $c = 0,867$  which is the lever arm factor which does not exceed  $0,95$  limiting  
Hence the lever arm  $z$  is  $0,867 \times 410 = 355\text{mm}$   
 $A_s$  required =  $M_{Rd}/f_{yd} z$  from Eqn (6.22)  
Using Grade 500 deformed austenitic stainless steel bars with a yield strength,  $f_{yk}$ , of  $500\text{N/mm}^2$  and with  $\gamma_M$  as  $1,15$  from the UK National Annex  
 $f_{yd} = 500/1,15 = 435\text{N/mm}^2$   
 $A_s$  required =  $86,40 \times 10^6 / 435 \times 355$   
 $A_s$  required =  $560\text{mm}^2$

**Therefore use 2no. deformed 20mm diameter bars, Austenitic stainless steel, strength Grade 500 (provides  $628\text{mm}^2$ ).**

This area of steel gives a reinforcement percentage of:  
 $628 \times 100 / 440 \times 410 = 0,35\%$   
which exceeds the minimum value of  $0,05\%$  from clause 8.2.3(1)

Limiting compressive design moment of resistance of beam:  
 $M_{Rd} = 0,27f_d b d^2$  from a consideration of a limiting uls compressive stress block of  $0,8 \times 0,4d$  in accordance with clause 6.6.2 and the EC6/EC2 methodology. *(It should be noted that EN 1996-1-1 increases this limiting  $M_{Rd}$  to  $0,4 f_d b d^2$  or  $0,3 f_d b d^2$  dependant upon masonry unit type and grouping for the specific design case of cantilever walls)*

$M_{Rd} = 0,27 \times 5,05 \times 440 \times 410^2 \times 10^{-6}$   
 $M_{Rd} = 100,85\text{kN.m}$   
This exceeds the applied design moment,  $M_{Ed}$ , of  $86,40\text{kN.m}$

### Section shear capacity

The design shear force,  $V_{Ed}$ , is  $82,10\text{kN}$

From Annex J for enhanced shear capacity of section incorporating vertical reinforcement:

Characteristic shear strength of section,  $f_{vd} = (0,35 + 17,5 \times \rho) / \gamma_M$  Eqn. J.1

Where  $\rho = A_s/bd = (628/440 \times 410) = 0,0035$

$f_{vd} = (0,35 + 17,5 \times 0,0035)/2,0 = 0,21\text{N/mm}^2$

And  $f_{vd} \leq 0,7/\gamma_M = 0,7/2,0 = 0,35\text{N/mm}^2$  limiting

$f_{vd}$  may be increased by the factor  $\chi = (2,5 - 0,25a_v/d)$

Where  $a_v = 86,40\text{kN.m}/82,10 \text{ kN} = 1,052\text{m}$

And  $a_v/d = 1052/410 = 2,566 < 6$  limiting

$\chi = (2,5 - 0,25 \times 2,566) = 1,859$

$f_{vd}$  enhanced =  $1,859 \times 0,21 \text{ N/mm}^2 = 0,39\text{N/mm}^2$

And  $f_{vd} \leq 1,75 / \gamma_M = 1,75/2,0 = 0,88\text{N/mm}^2$  limiting

Design shear resistance,  $V_{Rd1} = f_{vd} b d$  Eqn. 6.39

$V_{Rd1} = (0,39 \times 440 \times 410 \times 10^{-3}) = 70,36\text{kN}$

This is less than the applied design shear,  $V_{Ed}$ , of  $82,10\text{kN}$  and designed shear reinforcement is needed.

With designed shear reinforcement included:

$$V_{Ed} \leq V_{Rd1} + V_{Rd2}$$

where  $V_{Rd1} + V_{Rd2}$  is the total design shear resistance of the beam section  
 $V_{Rd2}$  is given by Eqn. 6.42 as:

$$V_{Rd2} = 0,9d \frac{A_{sw}}{s} f_{yd} (1 + \cot\alpha) \sin\alpha$$

where  $\alpha$  is angle of inclination of the shear reinforcement to the horizontal plane which is  $90^\circ$  here for vertically aligned shear links

and  $f_{yd} = 200/1,15 = 174\text{N/mm}^2$  for Grade 200 plain stainless steel bars

Therefore  $V_{Rd2} = (0,9 \times 410 \times A_{sw} \times 174/300) \times 1,0 \times 10^{-3} = 0,214A_{sw}$  kN  
where  $A_{sw}$  is the cross sectional area of the steel reinforcement required at 300mm horizontal centres which is the maximum spacing allowed as the lesser of 300 mm or  $0,75d$  (308 mm) from clause 8.2.7(6)

$$\text{Hence } 70,36 + 0,214A_{sw} = 82,10\text{kN}$$

$$\text{and } A_{sw} = 55\text{mm}^2$$

Check that the minimum area 0,05% shear steel is provided from clause 8.2.3(5)

$$\text{Minimum area} = 0.0005 \times 440 \times 410 = 90\text{mm}^2$$

**Use 8mm diameter plain bar Austenitic stainless steel, strength Grade 200 closed beam links at 300mm horizontal centres within concrete infill (provides  $101\text{mm}^2$ )**

Check limiting condition:

$$V_{Rd1} + V_{Rd2} \leq 0,25 f_d b d \quad \text{Eqn. 6.43}$$

$$\text{where } 0,25 f_d b d = 0,25 \times 5,05 \times 440 \times 410 \times 10^{-3} = 227,76 \text{ kN}$$

This is greater than,  $V_{Ed} = 82,10\text{kN}$  and therefore adequate.

**Secondary nominal links of 6mm diameter plain bar Austenitic stainless steel will also be required to tie into brickwork section and therefore link spacing of 300mm horizontally suits brickwork cross-joint spacing (75mm brick coursing multiples).**

**The anchorage bond of the tensile steel has not been considered in this example.**